

Geometry & Topology Monographs

Volume X: Volume name goes here

Pages 1–XXX

Stability in Controlled L -Theory

ERIK KJÆR PEDERSEN

MASAYUKI YAMASAKI

Abstract We prove a squeezing/stability theorem for delta-epsilon controlled L -groups when the control map is a polyhedral stratified system of fibrations on a finite polyhedron. A relation with boundedly-controlled L -groups is also discussed.

AMS Classification 18F25; 57R67

Keywords Controlled L -groups.

1 Introduction

Let us fix an integer $n \geq 0$, a continuous map $p_X: M \rightarrow X$ to a metric space X , and a ring R with involution. For each pair of positive numbers $\epsilon \leq \delta$, the delta-epsilon controlled L -group $L_n^{\delta, \epsilon}(X; p_X, R)$ is defined to be the set of equivalence classes of n -dimensional quadratic Poincaré R -module complexes on p_X of radius ϵ ($= n$ -dimensional ϵ Poincaré ϵ quadratic R -module complexes on p_X), where the equivalence relation is generated by Poincaré cobordisms of radius δ ($= \delta$ Poincaré δ cobordisms) [9] [10] [12]. If $\delta \leq \delta'$ and $\epsilon \leq \epsilon'$, there is a natural homomorphism

$$L_n^{\delta, \epsilon}(X; p_X, R) \rightarrow L_n^{\delta', \epsilon'}(X; p_X, R)$$

defined by relaxation of control. In general, this map is neither surjective nor injective. None the less, if X is a finite polyhedron and p_X is a polyhedral stratified system of fibrations in the sense of [5], the map above turns out to be an isomorphism for certain values of δ , δ' , ϵ , ϵ' :

Theorem 1 (Stability in Controlled L -groups) *For each integer $n \geq 0$ and a finite polyhedron X , there exist constants $\delta_0 > 0$ and $\kappa > 1$ such that the following hold: If*

- (1) $\kappa\epsilon \leq \delta \leq \delta_0$, $\kappa\epsilon' \leq \delta' \leq \delta'_0$, $\delta \leq \delta'$, $\epsilon \leq \epsilon'$,
- (2) $p_X: M \rightarrow X$ is a polyhedral stratified system of fibrations, and

(3) R is a ring with involution,

then the relax-control map $L_n^{\delta, \epsilon}(X; p_X, R) \rightarrow L_n^{\delta', \epsilon'}(X; p_X, R)$ is an isomorphism.

It follows that all the groups $L_n^{\delta, \epsilon}(X; p_X, R)$ with $\kappa\epsilon \leq \delta \leq \delta_0$ are isomorphic and are equal to the controlled L -group $L_n^c(X; p_X, R)$ of p_X with coefficient ring R .

Stability is a consequence of squeezing; squeezing/stability for controlled K_0 and K_1 -groups were known [3]. ‘Splitting’ was the key idea there. In section 2, we discuss splitting in the controlled L -theory. An element of a controlled L -group is represented by a quadratic Poincaré complex on a space. If it splits into small pieces lying over cone-shaped sets (*e.g.* simplices), then we can shrink all the pieces at the same time to obtain a squeezed complex. But splitting in L -theory requires a change of K -theoretic decoration; if you split a free quadratic Poincaré complex, then you get a projective one in the middle. Since the controlled reduced projective class group is known to vanish when the coefficient ring is \mathbb{Z} and the control map is UV^1 , we do not need to worry about the controlled K -theory and squeezing holds in this case [4].

Several years ago the first named author proposed an approach to squeezing/stability in controlled L -groups imitating the method of [3]. The idea was to use projective complexes to split and to eventually eliminate the projective pieces using the Eilenberg swindle :

$$\begin{aligned} [P] &= [P] + (-[P] + [P]) + (-[P] + [P]) + (-[P] + [P]) + \cdots \\ &= ([P] - [P]) + ([P] - [P]) + ([P] - [P]) + ([P] - [P]) + \cdots = 0 \quad . \end{aligned}$$

This approach works for any R if X is a circle; we will briefly discuss the proof in section 3.

The method used in section 3 does not generalize to higher dimensions, because it requires repeated application of splitting but that is not easy to do with projective complexes. This means that we should not try to shrink the complex globally, but should try to shrink a small part of the complex lying over a cone neighborhood of some point at a time. Such a local shrinking construction is possible when the control map is a polyhedral stratified system of fibrations, and is called an Alexander trick. We study its effect in section 4, and use it repeatedly to prove Theorem 1 in section 5. Note that we do one splitting of the whole complex for each application of an Alexander trick; we are not splitting the split pieces.

In section 6, we discuss several variations of Theorem 1.

Finally, in section 7, we relate the delta-epsilon controlled L -groups to the bounded L -groups in a special case.

The authors would like to thank Frank Connolly, Jim Davis, Frank Quinn and Andrew Ranicki for invaluable suggestions.

2 Glueing and Splitting

In this section we review techniques called glueing and splitting. If $p_X: M \rightarrow X$ is a control map and Y is a subset of X , then we denote the restriction $p_X|_Y$ of p_X by p_Y . A closed ϵ neighborhood of Y in X is denoted by Y^ϵ . We refer the reader to [9] [10] for terms and notations in controlled L -theory.

We first discuss the glueing operation; it is to take the union of two objects with common pieces of boundary. Suppose there are consecutive Poincaré cobordisms of radius δ , one from (C, ψ) to (C', ψ') and the other from (C', ψ') to (C'', ψ'') . Then their union is a Poincaré cobordism of radius 100δ from (C, ψ) to (C'', ψ'') (Proposition 2.8 of [10]). We will encounter this factor “100” many times in this article, and will denote it by μ at several places of section 5. For example, we will need the following, which is a special case of Proposition 3.7 of [10].

Proposition 2 *If $[C, \psi] = 0$ in $L_n^{\delta, \epsilon}(X; p_X, R)$, then there is a Poincaré cobordism of radius 100δ from (C, ψ) to 0.*

Proof By definition, there is a sequence of consecutive Poincaré cobordisms starting from (C, ψ) and ending at 0. Their union can be regarded as the union of the even-numbered ones and the odd-numbered ones, so it is 100δ Poincaré. \square

Next we discuss splitting. Before stating the splitting lemma, let us recall a minor technicality from §6 of [8]: Suppose X is the union of two closed subsets A and B with intersection $Y = A \cap B$. If a path $\gamma: [0, s] \rightarrow M$ with $p_X \gamma(0) \in A$ is contained in $p_X^{-1}(\{\gamma(0)\}^\epsilon)$, then it lies in $p_X^{-1}(A \cup Y^{2\epsilon})$. Of course it is contained also in $p_X^{-1}(A^\epsilon)$, but this is slightly less useful.

Lemma 3 (Splitting Lemma) *For any integer $n \geq 2$, there exists a positive number $\lambda \geq 1$ such that the following holds: If $p_X: M \rightarrow X$ is a map to a metric space X , X is the union of two closed subsets A and B with intersection Y ,*

and R is a ring with involution, then for any n -dimensional quadratic Poincaré R -module complex $c = (C, \psi)$ on p_X of radius ϵ , there exist a Poincaré cobordism of radius $\lambda\epsilon$ from c to the union $c' \cup c''$ of an n -dimensional quadratic Poincaré pair $c' = (f': P \rightarrow C', (\delta\bar{\psi}', -\bar{\psi}))$ on $p_{A \cup Y^{\lambda\epsilon}}$ of radius $\lambda\epsilon$ and an n -dimensional quadratic Poincaré pair $c'' = (f'': P \rightarrow C'', (\delta\bar{\psi}'', \bar{\psi}))$ on $p_{B \cup Y^{\lambda\epsilon}}$ of radius $\lambda\epsilon$, where $(P, \bar{\psi})$ is an $(n-1)$ -dimensional quadratic Poincaré projective R -module complex on $p_{Y^{\lambda\epsilon}}$ and P is $\lambda\epsilon$ chain equivalent to an $(n-1)$ -dimensional free chain complex on $p_{A \cup Y^{\lambda\epsilon}}$ and also to an $(n-1)$ -dimensional free chain complex on $p_{B \cup Y^{\lambda\epsilon}}$.

Proof This is an epsilon-control version of Ranicki's argument for the bounded control case [7]. For a given (C, ψ) of radius ϵ , pick up a subcomplex $C' \subset C$ such that C' is identical with C over A and C' lies over some neighborhood of A . Let $p: C \rightarrow C/C'$ be the quotient map and define C'' by the n -dual $(C/C')^{n-*}$. Define a complex E by the desuspension $\Omega\mathcal{C}(p\mathcal{D}_\psi p^*)$ of the algebraic mapping cone of the following map:

$$C'' = (C/C')^{n-*} \xrightarrow{p^*} C^{n-*} \xrightarrow{\mathcal{D}_\psi} C \xrightarrow{p} C/C' ,$$

where \mathcal{D}_ψ is the duality map $(1+T)\psi_0$ for ψ . There are natural maps $g': E \rightarrow C'$, $g'': E \rightarrow C''$ and adjoining quadratic Poincaré structures on them such that the union along the common boundary is homotopy equivalent to the original complex c . We should note that E is non-trivial in degrees -1 and n and that it lies over B .

Since \mathcal{D}_ψ is a small chain equivalence, its mapping cone is contractible. Therefore, E is contractible away from the union of A and a small neighborhood of Y , and it is chain equivalent to a projective chain complex P lying over a small neighborhood of Y by 5.1 and 5.2 of [8]. Note that \mathbb{Z} is used as the coefficient ring in [8], but the same argument works when the coefficient ring is replaced by R . Since $n \geq 2$, we can assume that P is strictly $(n-1)$ -dimensional (*i.e.* $C_i = 0$ for $i < 0$ and $i > n-1$) by the standard folding argument, and the chain equivalence induces a desired cobordism.

There is a quadratic Poincaré structure on a chain map $f': P \rightarrow C'$; therefore, the duality map gives a chain equivalence $C'^{n-*} \rightarrow \mathcal{C}(f')$, where $\mathcal{C}(f')$ denotes the algebraic mapping cone of $f': P \rightarrow C'$. Therefore

$$[P] = -([C'] - [P]) = -[\mathcal{C}(f')] = -[C'^{n-*}] = 0$$

in the epsilon controlled reduced projective class group of the union of A and a small neighborhood of Y with coefficient in R , and hence P is chain equivalent to a free $(n-1)$ -dimensional complex F' lying over the union of A and a small neighborhood of Y . \square

Remarks. (1) Suppose that X is a finite polyhedron or a finite cell complex in the sense of [11] more generally. Then there exist positive numbers $\epsilon_X > 0$, $\mu_X \geq 1$ and a homotopy $\{f_t\}: X \rightarrow X$ such that

- $f_0 = 1_X$,
- $f_t(\Delta) \subset \Delta$ for each cell Δ and for each $t \in [0, 1]$,
- f_t is Lipschitz with Lipschitz constant μ_X for each $t \in [0, 1]$, and
- $f_1((X^{(i)})^{\epsilon_X}) \subset X^{(i)}$ for every i , where $X^{(i)}$ is the i -skeleton of X .

Suppose $\{f_t\}$ is covered by a homotopy $\{F_t: M \rightarrow M\}$ and set $\delta_X = \epsilon_X \lambda$. If $\epsilon \leq \delta_X$ and A and B are subcomplexes of X , then by applying F_1 to the splitting given in the above lemma, we may assume that the pieces lie over A , B and $A \cap B$ respectively, instead of their neighborhoods, since the homotopy gives small isomorphisms between the corresponding pieces. But λ is now replaced by $\mu_X \lambda$ and it depends not only on n but also on X . We call such a deformation $\{f_t\}$ a *rectification* for X .

(2) The splitting formula for pairs given in [12] can be combined with 5.1 and 5.2 of [8] to prove a similar splitting lemma for pairs of dimension ≥ 3 : a sufficiently small Poincaré pair splits into two adjoining quadratic Poincaré triads whose common boundary piece is possibly a projective pair.

3 Squeezing over a Circle

We discuss squeezing over the unit circle. We use the maximum metric of \mathbb{R}^2 , so the unit circle looks like a square:

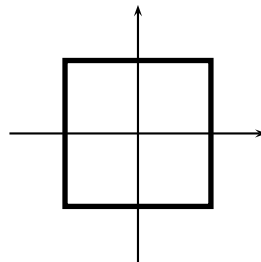

Consider a quadratic Poincaré R -module complex on the unit circle. We assume that its radius is sufficiently small so that it splits into four free pieces E, F, G, H with projective boundary pieces P, Q, S, T as shown in the picture below. The shadowed region is a cobordism between the original complex and the union of E, F, G, H . Although we actually measure the radius using the

radial projection to the unit circle (i.e. the square), we pretend that complexes and cobordisms are over the plane.

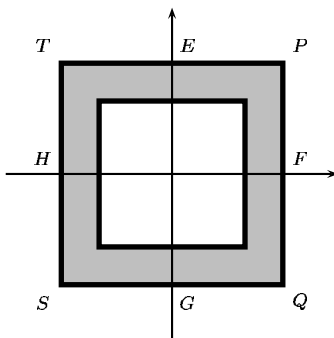

We extend this cobordism in the following way. On the right vertical edge, we have a quadratic pair $P \oplus Q \rightarrow F$. (We are omitting the quadratic structure from notation.) Take the tensor product of this with the symmetric complex of the unit interval $[0, 1]$. Make many copies of such a product and consecutively glue them one after the other to the cobordism. Do the same thing with the other three edges. Then fill in the four quadrants by copies of P, Q, S, T multiplied by the symmetric complex of $[0, 1]^2$ so that the whole picture looks like a huge square with a square hole at the center.

Although this cobordism is made up of free complexes and projective complexes, the projective complexes sitting on the white edges are shifted up 1 dimension, and the projective complexes sitting at the lattice points are shifted up 2 dimension in the union.

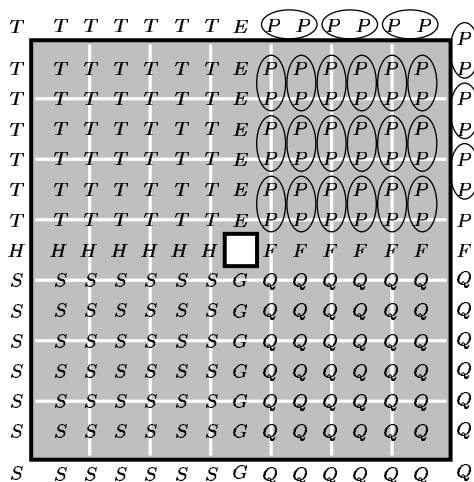

We can make pairs of these (as shown in the picture above for P 's) so that each pair contributes the trivial element in the controlled reduced projective class group. Replace each pair by a free complex.

Unlike the real Eilenberg swindle, there are four projective complexes left which do not make pairs. We may assume that they are the boundary pieces of F and H on the outer end. Since the two pairs $P \oplus Q \rightarrow F$, $S \oplus T \rightarrow H$ are Poincaré, the unions $P \oplus Q$ and $S \oplus T$ are locally chain equivalent to free complexes. Thus we can replace them by free complexes, and now everything is free.

Now recall that we actually measure things by a radial projection to the square. Thus we have a cobordism from the original complex to another complex of very small radius. If we increase the number of layers in the construction, the radius of the outer end becomes arbitrarily small. This is the squeezing in the case of S^1 .

4 Alexander Trick

The method in the previous section does not work for higher dimensional complexes, because we cannot inductively split the projective pieces. But the proof suggests an alternative way toward squeezing/stability. This is the topic of this section. Although we used a radial projection to measure the size in the previous section, we draw pictures of things in their real sizes in this section.

Let us fix an integer $n \geq 2$ and a finite polyhedron X . All the complexes below are R -module complexes, where R is a ring with involution. We assume that the control map $p_X: M \rightarrow X$ is a polyhedral stratified system of fibrations [5]; p_X is fiber homotopy equivalent to a map $q_X: N \rightarrow X$ which has an iterated mapping cylinder decomposition in the sense of Hatcher [2]: there is a partial order on the set of the vertices of X such that, for each simplex Δ of X ,

- (1) the partial order restricts to a total order of the vertices of Δ

$$v_0 < v_1 < \dots < v_k ,$$

- (2) $q_X^{-1}(\Delta)$ is the iterated mapping cylinder of a sequence of maps

$$F_{v_0} \longrightarrow F_{v_1} \longrightarrow \dots \longrightarrow F_{v_k} ,$$

- (3) the restriction $q_X|_{q_X^{-1}(\Delta)}$ is the natural map induced from the iterated mapping cylinder structure of $q_X^{-1}(\Delta)$ above and the iterated mapping cylinder structure of Δ coming from the sequence

$$\{v_0\} \longrightarrow \{v_1\} \longrightarrow \dots \longrightarrow \{v_k\} .$$

An order on the set of the vertices of X is said to be **compatible with** p_X if it is compatible with this partial order. Let us fix an order compatible with p_X .

Pick a vertex v of X , and let A be the star neighborhood of v , B be the closure of the complement of A in X , and S be the union of the simplices in A whose vertices are all $\geq v$ with respect to the chosen order. This will be called the *stable set* at v . Let $s: A \rightarrow S$ be the simplicial retraction defined by

$$s(v') = \begin{cases} v & \text{if } v' < v, \\ v' & \text{if } v' \geq v, \end{cases}$$

for vertices v' of A . A strong deformation retraction $s_t: A \rightarrow A$ is defined by $s_t(a) = (1-t)a + ts(a)$ for $a \in A$ and $t \in [0, 1]$. Note that this strong deformation retraction s_t is covered by a deformation \tilde{s}_t on M , since p_X is a polyhedral stratified system of fibrations.

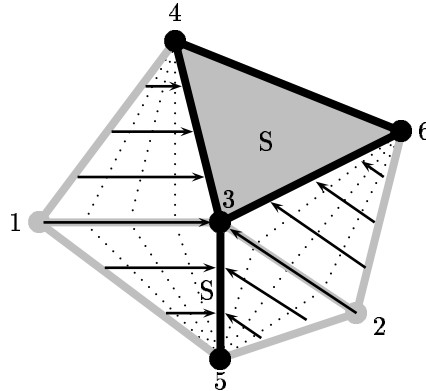

Given a sufficiently small n -dimensional quadratic Poincaré complex $c = (C, \psi)$ on p_X , one can split it according to the splitting of X into A and B : c is cobordant (actually homotopy equivalent) to the union c' of a projective quadratic Poincaré pair $a = (f: P \rightarrow F, (\delta\psi', \psi'))$ on p_A and a projective quadratic Poincaré pair $b = (g: P \rightarrow G, (\delta\psi'', -\psi'))$ on p_B , where F is an n -dimensional chain complex on p_A , G is an n -dimensional chain complex on p_B , and P is an $(n-1)$ -dimensional projective chain complex on $p_{A \cap B}$. Here we again used the assumption on p_X . See the remark after the splitting lemma.

Make many copies of the product cobordism from the pair a to itself, and successively glue them to the cobordism between c and c' . This gives us a cobordism from c to a (possibly) projective complex as in the left picture below.

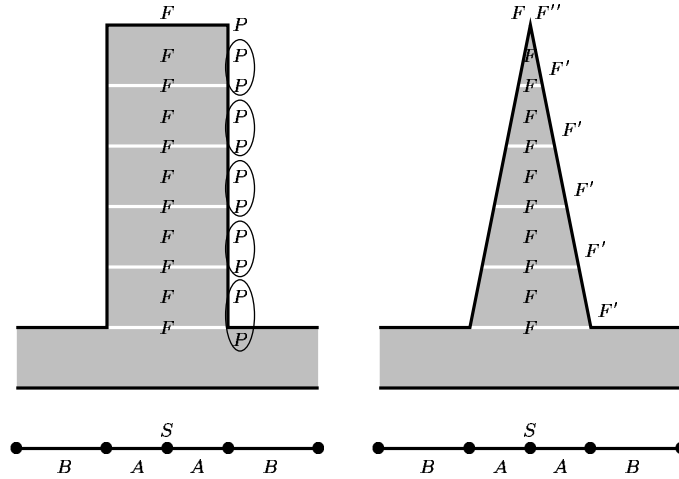

We will remedy the situation by replacing the projective end by a free complex as follows. The copies of P connecting the layers are actually shifted up 1 dimension in the union, so the marked pairs of P 's contribute the trivial element of the controlled \tilde{K}_0 group of $A \cap B$, and we can replace each pair with a free module by adding chain complexes of the form

$$0 \longrightarrow Q_i \xrightarrow{-1} Q_i \longrightarrow 0$$

lying over $A \cap B$, where Q_i is a projective module such that $P_i \oplus Q_i$ is free. Therefore, these pairs are all chain equivalent to some free chain complex F' . The last P remaining at the top of the picture can be replaced by some free complex F'' lying over A as stated in the splitting lemma.

We deform the tower, which is now free, toward S using \tilde{s}_t as in the picture above so that the top of the tower is completely deformed to S .

Summary *There exist constants $\delta > 0$ and $\lambda \geq 1$ which depend on n and X such that any n -dimensional quadratic Poincaré complex of radius $\epsilon \leq \delta$ on p_X is $\lambda\epsilon$ Poincaré cobordant to another complex which is small in the track direction of s_t . The more layers we use, the smaller the result becomes in the track direction.*

Remarks. (1) We cannot take $\lambda = 1$ in general, since the radius of the complexes gets bigger during the splitting/glueing processes.

(2) This construction will be referred to as the *Alexander trick* at v .

(3) There is also an *Alexander trick for pairs*. If we use the splitting lemma for pairs, then instead of a pair we get a Poincaré triad

$$\begin{array}{ccc} P & \longrightarrow & Q \\ \downarrow & \searrow & \downarrow \\ E & \longrightarrow & F \end{array}$$

over A , where P, Q are projective and E, F are free. Since both P and Q are free over A , we can carry out the construction exactly in the same manner as above. The effect on the boundary is exactly the same as the absolute Alexander trick.

(4) Take a simplex Δ of X with ordered vertices $v_0 < v_1 < \dots < v_n$. Let $(\lambda_0, \dots, \lambda_n)$ be the barycentric coordinates of a point $x \in \Delta$, *i.e.* $x = \sum \lambda_i v_i$. Then we define the *pseudo-coordinates* (x_1, \dots, x_n) of x by $x_i = \lambda_i / (\lambda_0 + \dots + \lambda_i)$. Actually x_i is indeterminate if $\lambda_0 = \dots = \lambda_i$. Let $s_{i,t}: \Delta \rightarrow \Delta$ be the restriction to Δ of the deformation retraction used for an Alexander trick at v_i ; then $s_{0,t} = 1_\Delta$ for every $t \in [0, 1]$, and $s_{i,t}$ preserves the pseudo-coordinate x_j for j not equal to i . This means that, roughly speaking, an Alexander trick at v_i improves the radius control in the x_i direction and changes the radius control in the x_j direction ($j \neq i$) only up to multiplications by the constant λ given in the Splitting Lemma and by the Lipschitz constant of $s_{i,t}$ which is uniform with respect to t . Thus, if we can perform appropriate Alexander tricks at all the vertices of Δ , then we can obtain an arbitrarily fine control over Δ . A more detailed discussion will be given in the next section.

Let us state a lemma on Lipschitz properties related to the homotopy s_t above, for future use.

Lemma 4 *Let X be a subset of \mathbb{R}^N with diameter d and $s: X \rightarrow X$ be a Lipschitz map with Lipschitz constant $K \geq 1$. Suppose X contains the line segment $xs(x)$ for every $x \in X$ and let $s_t(x) = ts(x) + (1-t)x$ for $t \in [0, a]$. Then $s_t: X \rightarrow X$ has Lipschitz constant K , and the map*

$$H: X \times [0, a] \rightarrow X \times [0, a]; \quad H(x, t) = (s_{t/a}(x), t)$$

has Lipschitz constant $\max\{d/a, 1\} + K$ with respect to the maximum metric on $X \times [0, a]$.

Proof Let x, y be points in X . Then

$$\begin{aligned} d(s_t(x), s_t(y)) &= \|t(s(x) - s(y)) + (1-t)(x - y)\| \\ &\leq td(s(x), s(y)) + (1-t)d(x, y) \\ &\leq tKd(x, y) + (1-t)Kd(x, y) = Kd(x, y) . \end{aligned}$$

Next, take two points $p = (x, t)$, $q = (y, u)$ of $X \times [0, a]$, and let $p' = (x, u)$. Then we have

$$\begin{aligned} d(H(p), H(q)) &\leq d(H(p), H(p')) + d(H(p'), H(q)) \\ &= \max\{d(s_{t/a}(x), s_{u/a}(x)), |t - u|\} + d(s_{u/a}(x), s_{u/a}(y)) \\ &\leq \max\{|t - u|d(s(x), x)/a, |t - u|\} + Kd(x, y) \\ &\leq |t - u| \max\{d/a, 1\} + Kd(x, y) \\ &\leq (\max\{d/a, 1\} + K) \max\{d(x, y), |t - u|\} \\ &= (\max\{d/a, 1\} + K)d(p, q) . \end{aligned}$$

□

5 Proof of Theorem 1

The algebraic theory of surgery on quadratic Poincaré complexes in an additive category [6] carries over nicely to the controlled setting, and can be used to prove a stable periodicity of the controlled L -groups. Therefore, we give a proof of the stability in the case $n \geq 2$. The stability for $n = 0, 1$ follows from the stability for $n = 4, 5$.

We first state the squeezing lemma for quadratic Poincaré complexes:

Lemma 5 (Squeezing of Quadratic Poincaré Complexes) *Let $n \geq 2$ be an integer and X be a finite polyhedron. There exist constants $\delta_0 > 0$ and $\kappa > 1$ such that the following hold: If $\epsilon < \epsilon' \leq \delta_0$, then any n -dimensional quadratic Poincaré R -module complex of radius ϵ' on a polyhedral stratified system of fibrations over X is $\kappa\epsilon'$ Poincaré cobordant to a quadratic Poincaré complex of radius ϵ .*

Proof Let X be a polyhedron in \mathbb{R}^N , and $p_X: M \rightarrow X$ be a polyhedral stratified system of fibrations. Order the vertices of X compatibly with p_X :

$$v_0 < v_1 < \cdots < v_m .$$

The basic idea is to apply the Alexander trick at each v_i . This should make the complex arbitrarily small in X as noted in the previous section. The problem is that an Alexander trick is made up of two steps: the first step is to make a tower using splitting, and the second step is to squeeze the tower, and estimating the effect of the splitting used in the first step is very difficult especially near the vertex when the object is getting smaller in a non-uniform way. To avoid this difficulty, we blow up the metric around each vertex so that the ordinary control on the new metric space insures us that the result has a desired small control measured on the original metric space X . Note that we are implicitly using this approach in the circle case.

Let us start from a complex c of radius $\epsilon' > 0$ on X . Since X is a finite polyhedron, there exist $\delta > 0$ and $\lambda \geq 1$ such that if $\epsilon' \leq \delta$ then c is $\lambda\epsilon'$ cobordant to the union of two pieces according to the splitting of X into two subpolyhedra as in the remark after Lemma 3. Recall that δ and λ depends on X . Set $\mu = 100$, and set $\delta_0 = \delta/(\mu\lambda^2)^{m-1}$. The factor 100 comes from 2.8 of [10] as was mentioned in §2. We claim that if $\epsilon' \leq \delta_0$, then a successive application of Alexander tricks produces a cobordism from c to a complex of radius ϵ .

Let us fix some more notation. V_1, \dots, V_m are the star neighborhoods of v_1, \dots, v_m , and L_1, \dots, L_m are the links of v_1, \dots, v_m ; V_i is the cone over L_i with vertex v_i for each i . S_1, \dots, S_m are the stable sets at v_1, \dots, v_m . $K \geq 1$ is the Lipschitz constant which works for every retraction $s_i: V_i \rightarrow S_i$ used for the Alexander trick at v_i . Let d denote the diameter of X , and let $\sharp(X)$ denote the number of simplices of X . Now fix a number $H \geq 1$ such that

$$H > d \quad \text{and} \quad 4\mu\sharp(X)(K+1)^m(\mu\lambda^2)^m\epsilon' \cdot \frac{d}{H} < \epsilon.$$

We inductively define metric spaces and subsets

$$X_*^{i,j} \supset X^{i,j} \supset V_k^{i,j} \supset L_k^{i,j} \quad (1 \leq i \leq j < k \leq m)$$

together with control maps $p_*^{i,j}: M_*^{i,j} \rightarrow X_*^{i,j}$ as follows.

Identify \mathbb{R}^N with the subset $\mathbb{R}^N \times \{0\}$ of $\mathbb{R}^{N+1} = \mathbb{R}^N \times \mathbb{R}$ with the maximum product metric. For each $i = 1, \dots, m$, define $X_*^{i,i}$ and its subsets $X^{i,i}$, $V_k^{i,i}$,

$L_k^{i,i}$ ($k = i + 1, \dots, m$) by

$$\begin{aligned} X_*^{i,i} &= X \cup (V_i \times [0, H]) , \\ X^{i,i} &= (X - V_i) \cup (L_i \times [0, H]) \cup (V_i \times \{H\}) , \\ V_k^{i,i} &= (V_k - V_i) \cup (V_k \cap L_i \times [0, H]) \cup (V_k \cap V_i \times \{H\}) , \\ L_k^{i,i} &= (L_k - V_i) \cup (L_k \cap L_i \times [0, H]) \cup (L_k \cap V_i \times \{H\}) . \end{aligned}$$

The projection $\mathbb{R}^N \times \mathbb{R} \rightarrow \mathbb{R}^N$ restricts to a retraction $r_{i,i}: X_*^{i,i} \rightarrow X$. We define the control map $p_*^{i,i}: M_*^{i,i} \rightarrow X_*^{i,i}$ to be the pullback of $p_X: M \rightarrow X$ via $r_{i,i}$, and define the control map $p^{i,i}: M^{i,i} \rightarrow X^{i,i}$ to be the restriction of $p_*^{i,i}$ to $M^{i,i}$. Note that the stereographic projection from $(v_i, -H) \in \mathbb{R}^N \times \mathbb{R}$ defines a homeomorphism $X \rightarrow X^{i,i}$ sending V_k and L_k to $V_k^{i,i}$ and $L_k^{i,i}$ respectively, since V_i is the cone on L_i with center v_i .

Next, for each $i = 1, \dots, m - 1$, define $X_*^{i,i+1} \subset \mathbb{R}^N \times \mathbb{R} \times \mathbb{R}$ and its subsets $X^{i,i+1}$, $V_k^{i,i+1}$, $L_k^{i,i+1}$ ($k = i + 2, \dots, m$) by

$$\begin{aligned} X_*^{i,i+1} &= X^{i,i} \cup (V_{i+1}^{i,i} \times [0, H]) , \\ X^{i,i+1} &= (X^{i,i} - V_{i+1}^{i,i}) \cup (L_{i+1}^{i,i} \times [0, H]) \cup (V_{i+1}^{i,i} \times \{H\}) \subset X^{i,i} \times \mathbb{R} , \\ V_k^{i,i+1} &= (V_k^{i,i} - V_{i+1}^{i,i}) \cup (V_k^{i,i} \cap L_{i+1}^{i,i} \times [0, H]) \cup (V_k^{i,i} \cap V_{i+1}^{i,i} \times \{H\}) , \\ L_k^{i,i+1} &= (L_k^{i,i} - V_{i+1}^{i,i}) \cup (L_k^{i,i} \cap L_{i+1}^{i,i} \times [0, H]) \cup (L_k^{i,i} \cap V_{i+1}^{i,i} \times \{H\}) . \end{aligned}$$

Again we use the product metric of $\mathbb{R}^N \times \mathbb{R}$ and \mathbb{R} . The projection $\mathbb{R}^N \times \mathbb{R} \times \mathbb{R} \rightarrow \mathbb{R}^N \times \mathbb{R}$ restricts to a retraction $r_{i,i+1}: X_*^{i,i+1} \rightarrow X^{i,i}$. The control maps $p_*^{i,i+1}: M_*^{i,i+1} \rightarrow X_*^{i,i+1}$ and $p^{i,i+1}: M^{i,i+1} \rightarrow X^{i,i+1}$ are defined to be the pullbacks of $p_*^{i,i}$ via $r_{i,i+1}$ and $r_{i,i+1}|_{X^{i,i+1}}$, respectively. Although $V_{i+1}^{i,i}$ is not a cone, it is homeomorphic to V_{i+1} and has a topological cone structure. So one can construct a homeomorphism from $X^{i,i+1}$ to $X^{i,i}$ sending $V_k^{i,i+1}$ and $L_k^{i,i+1}$ to $V_k^{i,i}$ and $L_k^{i,i}$ respectively, and hence a homeomorphism to X .

We can continue this to inductively obtain the metric space

$$X_*^{i,j} = X^{i,j-1} \cup (V_j^{i,j-1} \times [0, H])$$

as a subset of $\mathbb{R}^N \times \mathbb{R}^{j-i+1}$, and its subsets $X^{i,j} \supset V_k^{i,j} \supset L_k^{i,j}$ ($k = j + 1, \dots, m$), together with control maps $p_*^{i,j}: M_*^{i,j} \rightarrow X_*^{i,j}$, and $p^{i,j}: M^{i,j} \rightarrow X^{i,j}$. Topologically all the spaces $X^{i,j}$'s are equal to X , and all the sets $V_k^{i,j}$'s are equal to V_k . We are only changing the metric, the cell structure of X , and the control map.

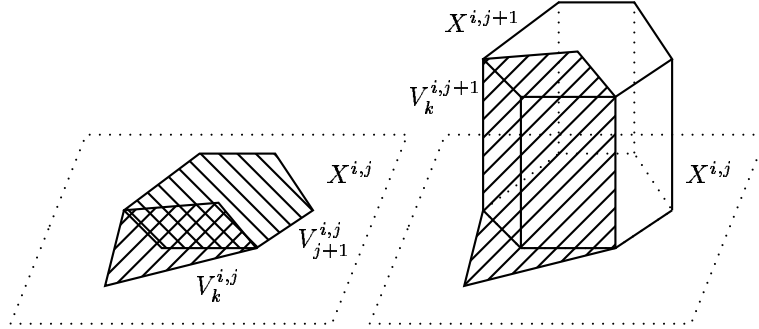

Our next task is to do Alexander tricks at v_1, \dots, v_m on these spaces instead of X . Since $\epsilon' \leq \delta_0 \leq \delta$, we can split the original complex c into two pieces on V_1 and the closure of its complements by a $\lambda\epsilon'$ cobordism. Now we construct a tower: we make copies of the trivial cobordism from the pair on (V_1, L_1) to itself and successively attach them to the cobordism along $V_1 \times [0, H]$. This is actually done on $M_*^{1,1}$.

We use enough layers so that the result is a projective cobordism of radius $\mu\lambda\epsilon'$ measured on $X_*^{1,1}$ from $c = \bar{c}_0$ to a complex c'_1 on $p^{1,1}$. Recall $\mu = 100$ and it comes from taking a union of Poincaré cobordisms. As described in previous sections, we can replace this by a free cobordism of radius $\mu\lambda^2\epsilon'$ from c to a free complex \bar{c}_1 on $p^{1,1}$.

We postpone the squeezing to a later stage and go ahead to perform Alexander trick over $V_2^{1,1} \subset X^{1,1}$ on \bar{c}_1 . Although $X^{1,1}$ has a different metric from X , the difference lies along the cylinder $L_1 \times [0, H]$. If H is sufficiently large, then a rectification for $X^{1,1}$ can be easily constructed from those for X and $[0, H]$, and the δ and λ for X works also for $X^{1,1}$. Since $\mu\lambda^2\epsilon' \leq \delta$, we can do splitting and cut out the portion on $V_2^{1,1}$ by a $\mu\lambda^3\epsilon'$ cobordism. Again use enough copies of this to get a $\mu^2\lambda^3\epsilon'$ cobordism on $p_*^{1,2}$ to a complex \bar{c}'_2 on $p^{1,2}$ and then replace this by free $\mu^2\lambda^4\epsilon'$ cobordism to a free complex \bar{c}_2 on $p^{1,2}$. Since $\epsilon' \leq \delta_0$, we can continue this process to obtain a consecutive sequence of free cobordisms:

$$c = \bar{c}_0 \xrightarrow{X_*^{1,1}} \bar{c}_1 \xrightarrow{X_*^{1,2}} \bar{c}_2 \cdots \bar{c}_{m-2} \xrightarrow{X_*^{1,m-1}} \bar{c}_{m-1} \xrightarrow{X_*^{1,m}} \bar{c}_m$$

Now we construct a map $S^{1,m}: X^{1,m} \rightarrow X$ and a map $\tilde{S}^{1,m}: M^{1,m} \rightarrow M$ which covers $S^{1,m}$ so that the functorial image of \bar{c}_m has the desired property. This is done by inductively constructing maps $S_*^{i,j}: X_*^{i,j} \rightarrow X$ and its restriction

$S^{i,j}: X^{i,j} \rightarrow X$ covered by maps $\tilde{S}_*^{i,j}: M_*^{i,j} \rightarrow M$ and $\tilde{S}^{i,j}: M^{i,j} \rightarrow M$, respectively, for certain pairs $j \geq i$.

First we define $S_*^{i,i}: X_*^{i,i} \rightarrow X$. Let us recall that $S_i \subset V_i$ denotes the stable set at v_i . Using the strong deformation retraction $s_{i,t}: V_i \rightarrow V_i$, define a map $S'_i: X_*^{i,i} \rightarrow X_*^{i,i}$ by:

$$(x, h) \mapsto \begin{cases} (x, 0) & \text{if } x \in X \text{ and } h = 0, \\ (s_{i,h/H}(x), h) & \text{if } x \in V_i \text{ and } h > 0. \end{cases}$$

This map is covered by a map $\tilde{S}'_i: M_*^{i,i} \rightarrow M_*^{i,i}$.

Lemma 6 S'_i has Lipschitz constant $K + 1$.

Proof This is obtained by applying Lemma 4 to the sets of the form $\{x\} \cup V_i$ for $x \in X - V_i$, extending the map s_i on x by $s_i(x) = x$. \square

$S_*^{i,i}: X_*^{i,i} \rightarrow X$ is defined by composing S'_i with the projection $r_{i,i}: X_*^{i,i} \rightarrow X$. It has Lipschitz constant $K + 1$. Since $r_{i,i}$ is obviously covered by a map $M_*^{i,i} \rightarrow M$, the map $S_*^{i,i}$ is covered by a map $\tilde{S}_*^{i,i}: M_*^{i,i} \rightarrow M$. Define $S^{i,i}: X^{i,i} \rightarrow X$ to be the restriction of $S_*^{i,i}$.

Now recall that $X_*^{1,2}$ and $X^{2,2}$ are obtained by attaching $V_2^{1,1} \times [0, H]$ and $V_2 \times [0, H]$ to $X^{1,1}$ and X , respectively. Since $S^{1,1}: X^{1,1} \rightarrow X$ maps $V_2^{1,1}$ to V_2 , the product map $S^{1,1} \times 1_{[0,H]}: X^{1,1} \times [0, H] \rightarrow X \times [0, H]$ restricts to a map $S^{1,1} \times 1|: X_*^{1,2} \rightarrow X_*^{2,2}$. Compose this with $S_*^{2,2}: X_*^{2,2} \rightarrow X$ to define $S_*^{1,2}: X^{1,2} \rightarrow X$ which is covered by a map $\tilde{S}_*^{1,2}: M_*^{1,2} \rightarrow M$. Continue this process as in the following diagram to eventually get the desired map $S^{1,m}: X^{1,m} \rightarrow X$.

$$\begin{array}{ccc} X^{1,j-1} & \xrightarrow{S^{1,j-1}} & X \\ \downarrow & & \downarrow \\ X_*^{1,j} & \xrightarrow{S^{1,j-1} \times 1|} X_*^{j,j} & \xrightarrow{S_*^{j,j}} X \\ & \searrow S_*^{1,j} & \parallel \\ X^{1,j} & \xrightarrow{S^{1,j}} & X \end{array}$$

Recall that there is a topological identification of $X^{1,m}$ with X . So we can think of $S^{1,m}$ to be a map from X to X equipped with different metrics. Although

it is not a homeomorphism, it preserves all the simplices, *i.e.* $S^{1,m}(\Delta) = \Delta$ for every simplex Δ of X . When restricted to a simplex, $S^{1,m}$ has Lipschitz constant $(K + 1)^m d/H$.

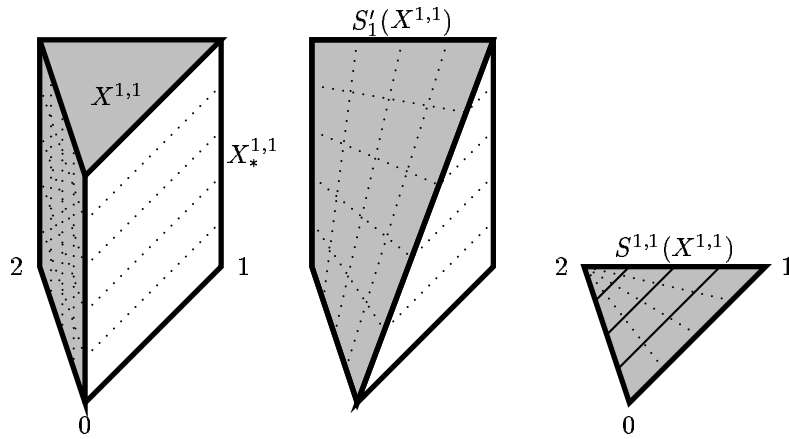

The three pictures above illustrate the application of $S^{1,1}$ to $X^{1,1}$. The thin solid lines in the rightmost picture indicate the direction in which controls are obtained.

The three pictures below illustrate the application of $S^{1,2}$ to $X^{1,2}$. The leftmost picture shows the image $(S^{1,1} \times 1)(X^{1,2}) = X^{2,2}$. Again the thin solid lines on the faces indicate the directions in which controls are obtained.

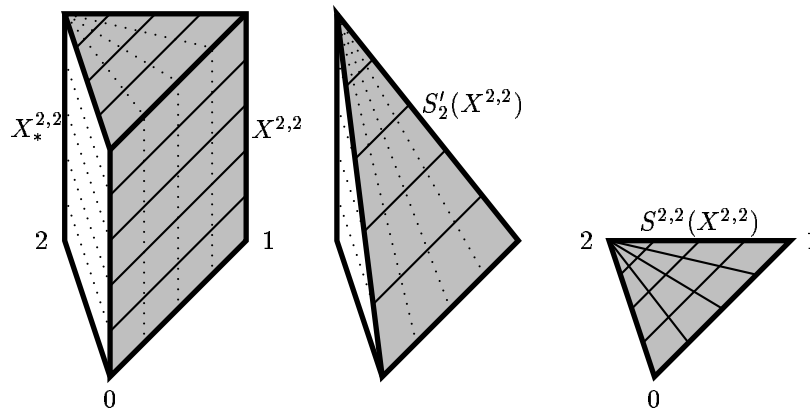

Let us consider the functorial image c_m of \bar{c}_m by the map $\tilde{S}^{1,m}: M^{1,m} \rightarrow M$. Recall that \bar{c}_m has radius $\epsilon'' = (\mu\lambda^2)^m \epsilon'$. Take a ball B of radius ϵ'' with in $X^{1,m}$. B is the union of subsets $B \cap \Delta$ each having diameter $2\epsilon''$, where Δ are the simplices of $X^{1,m}$. The images of $B \cap \Delta$ in X by $S^{1,m}$ all have diameter $2(K+1)^m \epsilon'' d/H$ and their union $S^{1,m}(B)$ is connected. Therefore $S^{1,m}(B)$ has diameter $2\sharp(X)(K+1)^m \epsilon'' d/H$. Thus c_m has radius

$$4\sharp(X)(K+1)^m (\mu\lambda^2)^m \epsilon' d/H ,$$

and this is smaller than ϵ by the choice of H .

It remains to find a constant κ such that c and c_m are $\kappa\epsilon'$ cobordant. Define a complex c_i on p_X to be the functorial image of \bar{c}_i by the map $\tilde{S}^{1,i}: M^{1,i} \rightarrow M$. The functorial image of the $(\mu\lambda^2)^i \epsilon'$ cobordism between \bar{c}_{i-1} and \bar{c}_i by the map $\tilde{S}_*^{1,i}$ gives a $4\sharp(X)(K+1)^i (\mu\lambda^2)^i \epsilon'$ cobordism between c_{i-1} and c_i . Composing these we get a $4\mu\sharp(X)(K+1)^m (\mu\lambda^2)^m \epsilon'$ cobordism between c and c_m . Thus $\kappa = 4\mu\sharp(X)(K+1)^m (\mu\lambda^2)^m$ works. This completes the proof. \square

Note that Lemma 5 implies that the relax-control map in Theorem 1 is surjective: Take an element $[c'] \in L_n^{\delta', \epsilon'}(X; p_X, R)$ with $\delta' \leq \delta_0$. Then the inequality $\epsilon' \leq \delta_0$ holds and therefore there is a Poincaré cobordism of radius $\kappa\epsilon'$ ($\leq \delta_0$) from c' to a quadratic Poincaré complex c of radius ϵ , determining an element $[c] \in L_n^{\delta, \epsilon}(X; p_X, R)$ whose image under the relax-control map is $[c']$.

Squeezing for complexes can be generalized to squeezing for pairs.

Lemma 7 (Squeezing of Quadratic Poincaré Pairs) *Let $n \geq 2$ be an integer and X be a finite polyhedron. There exist constants $\delta_0 > 0$ and $\kappa > 1$ such that the following hold: If $\delta < \epsilon' \leq \delta' \leq \delta_0$, then any $(n+1)$ -dimensional quadratic Poincaré R -module pair of radius δ' on a polyhedral stratified system of fibrations over X with ϵ' Poincaré boundary is $\kappa\delta'$ Poincaré cobordant to a quadratic Poincaré pair of radius ϵ . The cobordism between the boundary is $\kappa\epsilon'$ Poincaré.*

Proof Same as the proof of Lemma 5. Use the Alexander trick for pairs. \square

Corollary 8 (Relative Squeezing of Quadratic Poincaré Pairs) *Let $n \geq 2$ be an integer and X be a finite polyhedron. There exist constants $\delta_0 > 0$ and $\kappa > 1$ such that the following hold: If $\kappa\epsilon < \delta' \leq \delta_0$, then any $(n+1)$ -dimensional quadratic Poincaré R -module pair of radius δ' on a polyhedral stratified system of fibrations over X with an ϵ Poincaré boundary is $\kappa\delta'$ Poincaré cobordant fixing the boundary to a quadratic Poincaré pair of radius $\kappa\epsilon$.*

Proof Temporarily choose δ_0 and κ as in Lemma 7. Suppose $\kappa\epsilon < \delta' \leq \delta_0$, and let $d = (f: C \rightarrow D, (\delta\psi, \psi))$ be an $(n+1)$ -dimensional quadratic Poincaré pair of radius δ' , and assume that (C, ψ) is ϵ Poincaré. Choose a positive number $\epsilon' < \epsilon$. By Lemma 7, d is $\kappa\delta'$ cobordant to a quadratic Poincaré pair $d' = (f': C' \rightarrow D', (\delta\psi', \psi'))$ of radius ϵ . Glue d' to the $\kappa\epsilon$ Poincaré cobordism between (C, ψ) and (C', ψ') to get a quadratic Poincaré pair $d'' = (f'': C \rightarrow D'', (\delta\psi'', \psi))$ of radius $100\kappa\epsilon$. By construction, $d \cup -d''$ is $100\kappa\delta'$ Poincaré null-cobordant. Thus 100κ works as the κ in the statement of the lemma. \square

The injectivity of the relax-control map follows from this: Temporarily let δ_0 and κ be as in Corollary 8, and suppose $\delta \leq \delta'$, $\epsilon \leq \epsilon'$, $\kappa\epsilon \leq \delta$. Take an element $[c]$ in the kernel of the relax control map

$$L_n^{\delta, \epsilon}(X; p_X, R) \rightarrow L_n^{\delta', \epsilon'}(X; p_X, R).$$

By Proposition 2, the quadratic complex $c = (C, \psi)$ of radius ϵ' is the boundary of an $(n+1)$ -dimensional quadratic Poincaré pair $(f: C \rightarrow D, (\delta\psi, \psi))$ of radius $100\delta'$. If $\delta' \leq \delta_0/100$, then $\kappa\epsilon \leq 100\delta' \leq \delta_0$, and by Corollary 8 the element $[c]$ is 0 in $L_n^{\kappa\epsilon, \epsilon}(X; p_X, R)$, and hence also in $L_n^{\delta, \epsilon}(X; p_X, R)$. So, by replacing δ_0 with $\delta_0/100$, we established the desired injectivity. This finishes the proof of Theorem 1.

6 Variations

6.1 Projective L -groups

There is a controlled analogue of projective L^p -groups. $L_n^{p, \delta, \epsilon}(X; p_X, R)$ is defined using ϵ Poincaré ϵ quadratic projective R -module complexes on p_X and δ Poincaré δ projective cobordisms. Similar stability results hold for these.

To get a squeezing result in the L^p -group case, we first take the tensor product of the given projective quadratic Poincaré complex c with the symmetric complex $\sigma(S^1)$ of the circle S^1 . By replacing it with a finite cover if necessary, we may assume that the radius of $\sigma(S^1)$ is sufficiently small. If the radius of c is also sufficiently small, we can construct a cobordism to a squeezed complex. Split the cobordism along $X \times \{\text{two points}\} \subset X \times S^1$ to get a projective cobordism from the original complex to a squeezed projective complex.

6.2 UV^1 control maps

When the control map is UV^1 , there is no need to use paths to define morphisms between geometric modules [4]. This simplifies the situation quite a lot, and we have:

Proposition 9 *Let $p_X: M \rightarrow X$ be a UV^1 map to a finite polyhedron. Then for any pair of positive numbers $\delta \geq \epsilon$, there is an isomorphism*

$$L_n^{\delta, \epsilon}(X; p_X, R) \cong L_n^{\delta, \epsilon}(X; 1_X, R)$$

for any ring with involution R and any integer $n \geq 0$.

By Theorem 1, the stability holds for $L_n^{\delta, \epsilon}(X; 1_X, R)$ and hence the stability holds also for $L_n^{\delta, \epsilon}(X; p_X, R)$.

6.3 Compact metric ANR's

Squeezing and stability also hold when X is a compact metric ANR, and the control map is a fibration. To see this, embed X in the Hilbert cube I^∞ . There is a closed neighborhood U of X of the form $P \times I^{\infty-N}$, where P is a polyhedron in I^N . Use the fact that the retraction from U to X is uniformly continuous to deduce the desired stability from the stability on P and U .

7 Relations to Bounded L -Theory

In this section we shall identify the controlled L -theory groups with a bounded L -theory group, at least in the case of constant coefficients. The main advantage to having a bounded controlled description, is that it facilitates computations.

Definition 10 Let X be a finite polyhedron and R a ring with involution. Let $p_X: X \times K \rightarrow X$ be a trivial fibration. We denote the common value of $L_n^{\delta, \epsilon}(X; p_X, R)$ for small values of δ and ϵ , which exists by Theorem 1, by $L_n^{h, c}(X; p_X, R)$. Here the h signifies that we have no simpleness condition and the c stands for controlled.

We may embed the finite polyhedron X in a large dimensional sphere S^n and consider the open cone $O(X) = \{t \cdot x \in R^{n+1} | t \in [0, \infty), x \in X\}$. We denote X with a disjoint basepoint added by X_+ .

Theorem 11 *Let $p_X: X \times K \rightarrow X$ be as above, $\pi = \pi_1(K)$, R a ring with involution. Then*

$$L_n^{c,h}(X; p_X, R) \cong L_{n+1}^s(\mathcal{C}_{O(X_+)}(R[\pi]))$$

where $\mathcal{C}_{O(X_+)}(R[\pi])$ denotes the category of free $R[\pi]$ modules parameterized by $O(X_+)$ and bounded morphisms.

Proof Given an element in $L_n^{c,h}(X; p_X, R)$, we can choose a stable (δ, ϵ) representative. Crossing with the symmetric chain complex of $(-\infty, 0]$ produces a bounded quadratic chain complex when we parameterize it by $O(+)$, which is obviously a half line, with $+$ being the extra basepoint. According to Theorem 1, we may produce a sequence of bordisms to increasingly smaller representatives of the given element in $L_n^{c,h}(X; p_X, R)$. These bordisms may be parameterized by $\{t \cdot x | x \in X, a_i < t < a_{i+1}\}$ where the sequence of a_i 's is chosen such that when these bordisms are glued together, we obtain a bounded quadratic complex parameterized by $O(X_+)$. We get an s -decoration because obviously we can split the bounded quadratic complex. The map in the opposite direction is given by a splitting obtained the same way as in Lemma 3. \square

One advantage of a categorical description is computational. We have as close an analogue to excision as is possible in the following: Let Y be a subcomplex of X , and S a ring with involution. We then get a sequence of categories

$$\mathcal{C}_{O(Y_+)}(S) \rightarrow \mathcal{C}_{O(X_+)}(S) \rightarrow \mathcal{C}_{O(X/Y)}(S)$$

which leads to a long exact sequence

$$\dots \rightarrow L_n^a(\mathcal{C}_{O(Y_+)}(S)) \rightarrow L_n^b(\mathcal{C}_{O(X_+)}(S)) \rightarrow L_n^c(\mathcal{C}_{O(X/Y)}(S)) \rightarrow \dots$$

where the rule to determine the decorations is that b can be chosen to be any involution preserving subgroup of $K_i(\mathcal{C}_{O(X_+)}(S))$, $i \leq 2$, but then c has to be the image in $K_i(\mathcal{C}_{O(X/Y)}(S))$, and a has to be the preimage in $K_i(\mathcal{C}_{O(Y_+)}(S))$. See [1] for a derivation of these exact sequences. This makes it possible to do extensive calculations with controlled L -groups.

References

- [1] **I Hambleton, E K Pedersen**, *Topological equivalence of linear representations for cyclic groups: II*, preprint (2002)
- [2] **A E Hatcher**, *Higher simple homotopy theory*, Ann. of Math., **102** (1975) 101 – 137

- [3] **E K Pedersen**, *Controlled algebraic K -theory, a survey*, *Geometry and Topology: Aarhus (1998)*, 351 – 368, Contemp. Math., **258**, Amer. Math. Soc., Providence, RI, 2000
- [4] **E Pedersen, F Quinn, A Ranicki**, *Controlled surgery with trivial local fundamental groups*, High dimensional manifold topology, Proceedings of the conference, ICTP, Trieste Italy, World Scientific (2003) 421 – 426
- [5] **F S Quinn**, *Ends of maps II*, Invent. Math. **68** (1982) 353 – 424
- [6] **A Ranicki**, *Additive L -Theory, K -theory*, **3** (1989) 163 – 195
- [7] ———, *Lower K - and L -Theory*, London Math. Soc. Lecture Note Series, **178**, Cambridge Univ. Press, 1992
- [8] **A Ranicki, M Yamasaki**, *Controlled K -theory*, Topology Appl. **61** (1995) 1 – 59
- [9] ———, *Controlled L -theory (preliminary announcement)*, Proceedings of the Conference in *Surgery and Geometric Topology*, Sci. Bull. Josai Univ. (1997) 119 – 136
- [10] ———, *Controlled L -theory*, preprint (2004), arXiv:math.GT/0402217
- [11] **C P Rourke, B J Sanderson**, *Introduction to Piecewise-Linear Topology*, Ergeb. Math.Grenzgeb. **69**, Springer-Verlag Berlin Heidelberg New York, 1972
- [12] **M Yamasaki**, *L -groups of crystallographic groups*, Invent. Math. **88** (1987) 571 – 602

Department of Mathematical Sciences, SUNY at Binghamton, Binghamton, New York 13901, USA

Department of Applied Science, Okayama University of Science, Okayama, Okayama 700-0005, Japan

Email: erik@math.binghamton.edu masayuki@mdas.ous.ac.jp